

BLOWLAMP NEWS

No 41

August

2002

Ten Years On

It is ten years since, in August 1992, I wrote the first tentative "Blowlamp News" to 32 people I had met at "Stourpaine" and other much smaller rally venues. In response to a discussion among a small group of collectors about how to keep in touch during the rest of the year, when rallies were over, I suggested a newsletter. There followed the inevitable finger pointing and "you had better do it then!" Altogether since then some 200 or more people have either become members or sought information because of their interest in blowlamps. Some joined and some did not and it surely cannot have been the cost of subscriptions! Some people indeed are not Society or Club persons. From that time a group of friends across the world has gathered together and seen the emergence of two other magazines - first the Gazette, now known as Nouvelle Gazette in France and the Torch in the U S A. The popularity of the collection and study of blowlamps has spread and the documentation of their history has increased into a vast and steadily growing data base. International meetings are now held annually in four countries and with the onset of e-mail a further means of communication has been established. We do not have the number of on-line members in this country to justify a web site over here and in any case the American based site has now been discontinued because of costs. However, there is an e-mail system known as a Community Web Site which I am investigating where the access is limited to members to exchange text and images and I am intending to set this up as soon as I can.

So Blowlamps are now in the electronic age.

However, with my thinking still in the age of steam, it is rapidly getting towards the time for me to hand over the reins. Thus I am looking for suggestions from members as to how the newsletters should be continued into the future. An offer is already on the table for the administration and recording of membership and my thinking is that a small editorial group should form to gather copy which can then be put together by a new editor and perhaps even a new means of production of the newsletters. Ideas please.

Sheila Hawkins

With great sadness I have to tell you of the death of Sheila on June 8th. She had been a keen supporter of Blowlamp News from her earliest association with Keith back in 1995 and had contributed material for several newsletters, notably in the form of reports on the shows they had both attended. In one issue, also, she gave valuable personal advice on how to negotiate with French *Brocante* vendors and this expertise, together with her knowledge of the French language, undoubtedly led to a considerable increase in Keith's collection.

She was always the social entertainer, providing numerous refreshments wherever their display was on show. I indeed recall one dinner in "The Castle," (as their caravan was dubbed for the night) in the relative squalor of "Stourpaine," where in other circumstances it would have been appropriate to dress with black tie. I do recall though that Keith wore his green blowlamp-encrusted waistcoat and who else but Sheila could have devised such a garment?

She was also a great supporter of our meetings and always an enthusiastic helper in the kitchen. Before her marriage to Keith, in September 1996, she had a distinguished career in the Health Services, notably in connection with disadvantaged children. This was not generally known until the funeral, which was so well attended by her former Health Service colleagues. The funeral service itself, because of her non religious beliefs, was unusual in that, by all accounts, it resembled those held in New Orleans accompanied by the appropriate jazz music.

All that now remains for me to say is to repeat, with feeling, the touching obituary heading which Michel Duval wrote in the Nouvelle Gazette - "Au revoir Sheila".

B/N 40 drawings

Logos

a) Hanau The American Hanau Engineering Co. made a neat upright black plastic alcohol fuelled lamp which was used by dentists. An intense pointed flame is created by a jet of air across the alcohol wick when a trigger mechanism on the handle is operated. It is illustrated on P 135 of Dick Sarpolus' book.

b) Sopletes ADIR A series of traditional looking blowlamps originating from Mexico. The photocopy was kindly supplied by Michel Duval. I am trying, through several sources in Mexico, to obtain more information about this company and whether they made or marketed these lamps

Lamps

a) La Lyonnaise No 2. A picture kindly sent by Ted Rawson. Nothing known about it so far.

b) "Phoenix" by The Decker Manufacturing Co. of Newark, New Jersey. Supplied by Tom Bartlett as a photograph!

c) Andy Feast states that his lamp is a Barthel "Roarer" but it bears no number. I understood that all "Roarer" lamps had a number which was followed by the letter "B". For example the lowest number I have is 4B with the highest 36B. What is the significance of the letter "B"? It appears to be superfluous to stand for Barthel and there is no evidence that a system such as the French "bis" existed in Germany. Any comments?

The 6B which was illustrated on the front cover of the Gazette, I drew in B/N 27. My 4B has a steel tank and probably dates from WW I and I was told many years ago by an Irish collector that he had a 4B with a brass tank. He didn't show me so I can't be sure if it was the Guinness talking! My 36 B also has a steel tank with a cane wound handle. In any case why "Roarer"?

Any suggestion that it may be compared with the Roarer version of the cooking stoves?

Snippets

Norman Penny brought his Valtock Soldering attachment to Bletchingley which I have drawn on P 4. The support stem in his attachment is straight whereas in the picture of the advertisement sent me by Sylvia Black it is cranked forward. Norman's was, I believe, attached to a Valtock "Major" and it does seem from the scale of the picture from Sylvia that that attachment was to a "2000" I wonder if there were two variants for the different size of lamp, though against this is the fact that the "Major" has a flame guard which projects beyond the front tube wick and thus if a cranked version were necessary it would be needed for the "Major" not the "2000" Anyone else have one to confirm or refute this theory?

Also at Bletchingley Norman had a vaporising device he found in a Surmelin. Similar in function, but much simpler in construction, to the Gasificateur in B/N 34. Illustration shown on P.4

He reports acquiring a steel tank Burmos 1943 G P O lamp with the caution about use embossed on a brass plaque soldered on the side of the tank. G P O is stamped on the side of the burner head and contrary to normal practice the handle is soldered on the tank

Paul Whiddett recently acquired a Swedish "R M Lamp". It is a 1/2 pint petrol lamp with inclined burner, a wooden control knob and cane wound handle. He sent me a rubbing of the logo from which I have drawn the illustration on P 4 I have never heard of this lamp. Has anyone else?

Ray Hyland sent a photograph of a 1 pint paraffin lamp with a pump in the handle and a soldered on plaque reading WNOTS. Very odd! Plaque on P 4

Questions

I have a photocopy of part of a leaflet on Three Crowns Lamps where the Printer's date is "Stockholm 1950". Pictures are of benzoline lamps No. 3 "Original Swedish Lamp" and No 15 with Nos. 20,22,23 mentioned. These are brazing lamps of similar pattern and probably increasing size though the size is NOT stated. The text describes the method of correcting the safety wire when the base bulges from overheating due to "preheating over open fire or gas flames" and the wire is seen in the illustration of the "Swedish Lamp" Also, its handle is cane wound and the control knob wooden. The Brazing lamp is shown to have a cord wound pump in the handle with both control knobs of wood

The caption on the form states "Guaranteed by 40 years concentrated study and experience" while on the transfer on the side of the "Swedish lamp" the period of guarantee of study etc is shown as 25 years.

Thus the illustrations are many years out of date with the text and date of the leaflet although it would appear that K F Eriksson was still making lamps in 1950.

So, we also need to seek evidence of when the change to spiral wire handles occurred and the material of the control knobs changed, together with the start of use of safety valves.

Anyone anything to add?

Nothing so far on Keith Hawkins' Japanese lamp which is a look-a-like for the Dixon L2 - a three ounce capacity glass bowled lamp with a ¼ in diameter wick. Those Japanese will copy anything!

Anyone found Paul Whiddett's number 5102 on their Paquelins?

Shows and Rallies

Taff - Great Dorset Steam Fair Aug 28 / Sept 1

Toon - G D S F Aug. 28 / Sept 1

Keith Hawkins - Honiton Hill Aug 24 / 26 G D S F Aug 28 / Sept 1

Norman Penny - Brooklands Farm, Ibsley Aug 10 / 11

Malcolm Farnsworth - Thurlow and Haverhil, Suffolk Aug 3 / 4;

Butterfields Farm, Latchingdon, Maldon, Essex Sept 8.

No news of any other shows by members. Do try to let me know next year in time for publication as I'm sure people are interested.

I've enclosed a pre-booking form for anyone coming to the Great Dorset Fair but remember you must get your application in before August 11th. I am not exhibiting there, so may well not be in my caravan all the time, but if you can let me know the day you are coming I can try to be available. Keith has offered to provide tea, coffee etc. and if arrangements are suitable I'll site his van next to mine so I hope to see and chat with some of you. Arne Aasgaard is hoping to come over from Norway so this may be an opportunity to meet yet another of our Continental members.

Bletchingley 2002

Once again this popular venue produced a full house with a good representation from across the Channel. We welcomed several new faces, at least one of whom was staggered by the sight of so many lamps and he was walking around most of the time with a bemused look on his face. His collection increased considerably that day. Among outstanding exhibits were Andy's display of three hundred lamps, and Keith Hawkins' which featured engine start lamps.

Certainly there were two stars. Robert Langlois' recently acquired **Sievert H S L 4** which he "unveiled" to envious gasps from the audience. This is a quite enormous, tall, narrow lamp which has a large double headed burner, each with a five coil preheat. Willy Mouton responded with his hand made version of the same lamp. This was a truly amazing replica which represented many hours of patient and accurate work. Having said "accurate" I must add that Willy admitted that the measurements were not exact since he did not have the benefit of a lamp to copy nor drawings with dimensions. Because of the slight variation from the original he preferred to call it an "**H S L 3.5**". Nevertheless two very impressive exhibits the like of which I think no one present had ever seen.

I believe that another first chalked up at the meeting was John Tingle's acquisition of a Surmelin 20, probably the first in England. Unless, that is, someone is very cautiously hiding one! Michel Duval again did well with his exchanges, adding ten different makes of blowlamp to his already large and very selective collection. Another interesting item was John Tingle's stock of American transfer "decals" to enhance the appearance of your American lamps. These are accurately produced in color (note the spelling!) and are available for a wide range of American torches. Produced by Bill Bennett in the States, I hope to have more details about them for the next B/N.

Only one problem, which caused Vera great concern, was the late arrival of the buffet lunch due to a misunderstanding of the timing by the caterer. However the wait merely increased our appetites and I don't think too many people were troubled by the delay. Our grateful thanks and congratulations go to Vera and her team

Reunion of the French Group

This is being held about ten miles away from the great cathedral city of Reims on Saturday September 28th and all are welcome. I understand that Andy is going, and he may even have a spare seat. Please contact Jacques Debrouwer on 03 86 36 22 23 for reservations as soon as possible. He is able to make hotel bookings if necessary. The meal, which sounds great, will cost 20 Euros to include wine. I have some maps and directions if anyone should need them

B/N 41 drawings

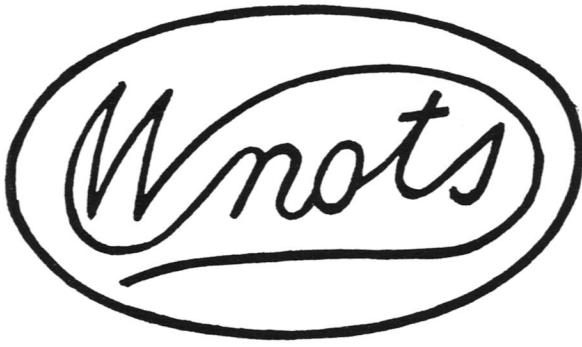

Ray Hyland's WNOTS plaque

Paul Whiddett's R M logo which is stamped into the tank



Norman Penny's

-vaporiser

Valtock soldering attachment -

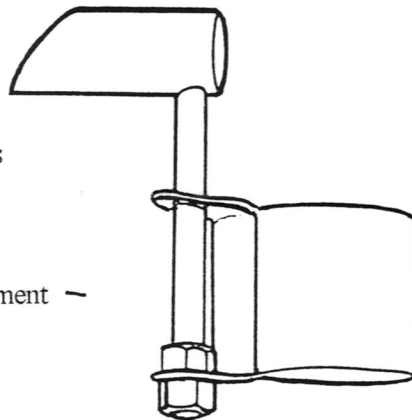

Two Fillers to identify and comment on

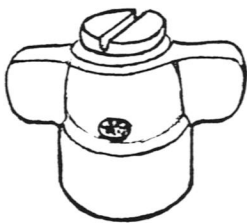

(a)

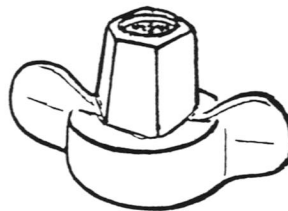

(b)

Four B/N 41 Blowlamps

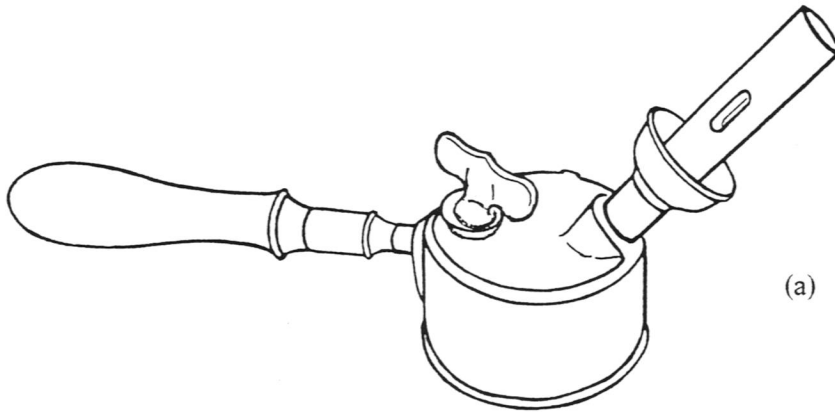

(a)

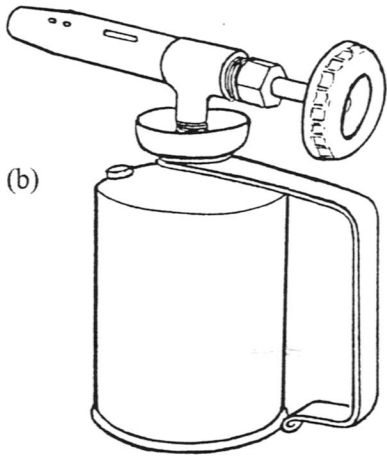

(b)

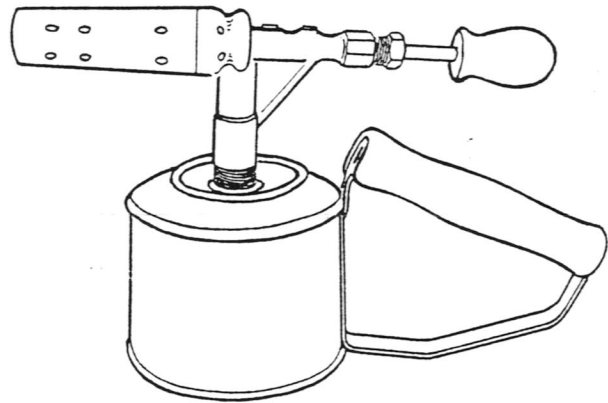

(c)

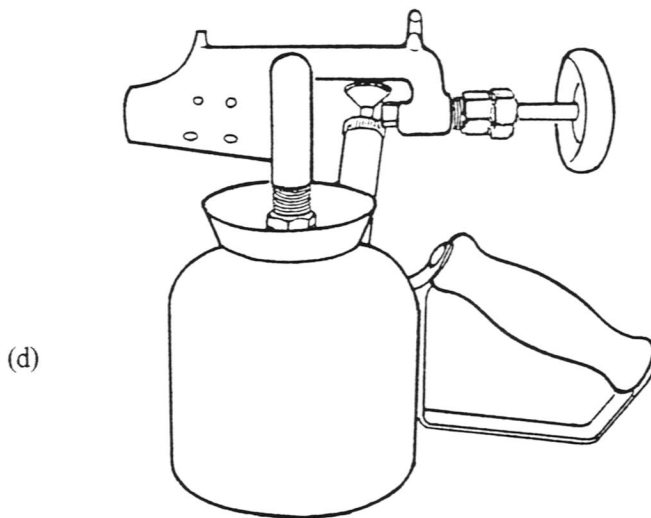

(d)

Spares

I had an e-mail enquiry recently about spares for a blowlamp which was being used to fire pottery (yet another use which I had not been aware of) This had been passed on by a person who supplies spares for kerosene cookers, lanterns etc. but not blowlamps. . Unfortunately I did not get any follow-up about the type of lamp or the spare required. The supplier of spares - Mike- can be contacted at spares@base-camp.co.uk and also on his web site www.base-camp.co.uk. I'd be interested to hear if anyone does any business with him and whether he has any spares which could be interchangeable with blowlamps.

News from other publications.

The latest "Nouvelle Gazette" from Michel Duval contains a moving obituary for Sheila, who of course, was well known at the French and Belgian meetings

The front page also bears a photograph of Robert Langlois at Bletchingley with his HSL no 4. Inside two pages are devoted to a comprehensive report on Express vertical lamps by Michel Duval but we shall need a translator for this

The latest "Torch" from Ron Carr contains a full report and catalogue of Turner products, which was largely compiled by Graham Stubbs. So there may well be some answers to questions about Turner lamps. Ron is also collecting Instruction and Service leaflets but naturally these will be mostly American. If anyone has something of interest like this please let me have a photocopy and I will touch it up for B/N and send on a copy to Ron for his collection. Most seem to be badly stained and sometimes incomplete but I am usually able to make a reasonable copy. In addition to Keith's earlier offer of replacement control knobs, Mark Pedersen also is able to provide these of American patterns together with the small lever controls which are often a feature - all accompanied with the original style small brass ferrules.

So we are now getting into the realms of real restoration. What we all need to know now is how to remove the work and time induced dents which mar some exhibits. Anyone care to produce an article or some information on this?

Membership details

Change of postal address

Henk KROON 5 Bishops Road Tewin WELWYN Herts AL6 0NR Phone 01438 - 798597

N.B (So you now know where to send for the badges he has left)

e-mail addresses

New Owen Pearson ---- opearson@btclick.com

" Ken Blackwell ---- Jean@Blackwell83.freemove.co.uk

" Lee McGuckian----elzemac@tiscali.co.uk

Graham Stubbs----gstubbs222@aol.com

Jon Suta-----jsuta@cnw.com

Mark Pedersen----pedleen@webtv.net

Larry Fields-----NCHRARef@triad.rr.com

Tom Morris----tom@themountguesthouse.co.uk

" Ray Gubb----- ray.gubb@btopenworld.com

Correction. Sylvia Black ---- silvanalanblackmanor@hotmail.com

" Russell Harrower ---- ruslor@talk21.com

Change. Dave Nichols ----davidnichols@btinternet.com

Brian Grainger----Mutleyb@aol.com

Welcome to new members

David CLARKE 13A Warrior Square Southend on Sea Essex SS1 2JN 01702 - 468738

John WEAVER 15 Bushey Thorn Road Chew Stoke Bristol BS40 8XP 01275 - 332972

If any of your details are not correct, or need updating, please let me know and I'll endeavour to put them right in the next B/N.

I look forward to meeting some of you at Blandford at the end of the month.

Cheers.



Blowlamp News its design and illustrations are Copyright ©