

# BLOWLAMP NEWS

DECEMBER

1998

No 27

## Identification

Our mystery T V personality of the Antiques Roadshow has now been revealed as Keith Hawkins. Perhaps when the venue was named one should have made a reasoned guess. However when Keith wrote to me recently he was a little miffed that he had not been recognised. What he didn't know was that the first intimation I had about the programme containing a reference to blowlamps was a totally unexpected phone call from my solicitor, who, perhaps fortunately, did not know Keith. What he did say to me was "there's another idiot on Telly who collects blowlamps".

But on to the Newsletter

Very few answers to questions asked in **B/N26**, but some follow-up to **B/N 25**.

Brian Grainger has a lamp which has the same markings as mine in B/N 25 (b) but nothing else and its burner is copper instead of brass. Since the similarity with Barthel has been raised here are representations of both the Barthel Roarer 4B and 6 B for comparison. My 4B has a one piece steel tank but I am told that one member has a brass tanked version. Answer is still awaited.

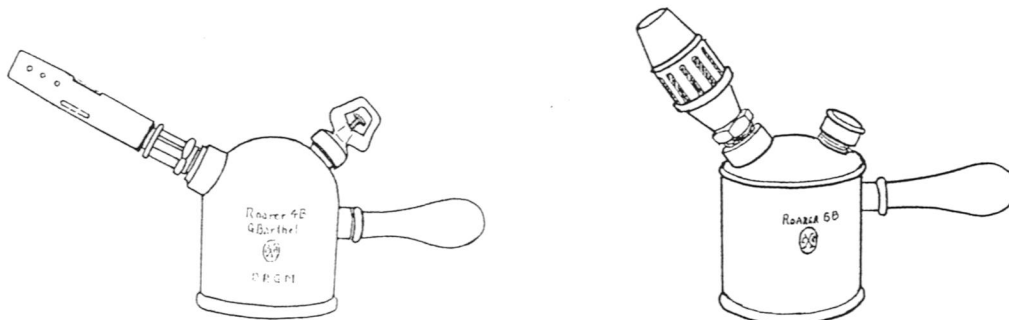

Brian also has some information about the Garrat and Fowler mouth blowlamp. He has a smaller version which unlike Ted Rawsons has the air inlet tube coming in from the base and turning at right angles to the burner tube. There is no valve control. It bears the patent date 1894. He also has two smaller types without handles but each has a pointed spur on the base to which a handle would probably not fix firmly. The air is supplied in the conventional way from the back of the body of the lamp. These are designated Garrat and Co. but the logos differ as do the numbers stamped on the front of the tanks - P 8176 and P 2321

### Clues to B/N 26 drawings.

#### Filler Caps

- is from an Optimus "Swedish Lamp" but I have seen the same form on a number of other Optimus lamps of possibly similar vintage.
- is the filler on a large vertical burner "Express" which has a steel tank. It does not bear a serial number and looks as if it could have been an engine starting lamp. The name is cast into the side of the cap
- is the filler on the "Anglo Swedish" lamp by John Shaw which I detailed as having the G P O caution in the form of an embossed soldered brass plaque on its side.

**B/N 26 Handles**

- a) A later-vintage "Wall" flat tanked tool box lamp uses this handle which is fixed with one screw into a bracket on the side of the steel tank . The name "Wall" is cast into the opposite side to the "Pistogrip" trade name. The lamp ( torch) bears no markings - does anyone have any clues to its designation?
- b) Another American handle this time from a "Hercules". A question about this brand was asked in an earlier newsletter but with no response. I have since acquired a "Hercules" "Self Generator" but have no further information about either.
- c) From a Canadian "Butler 200"

**B/N 27 Drawings**

**Burners**

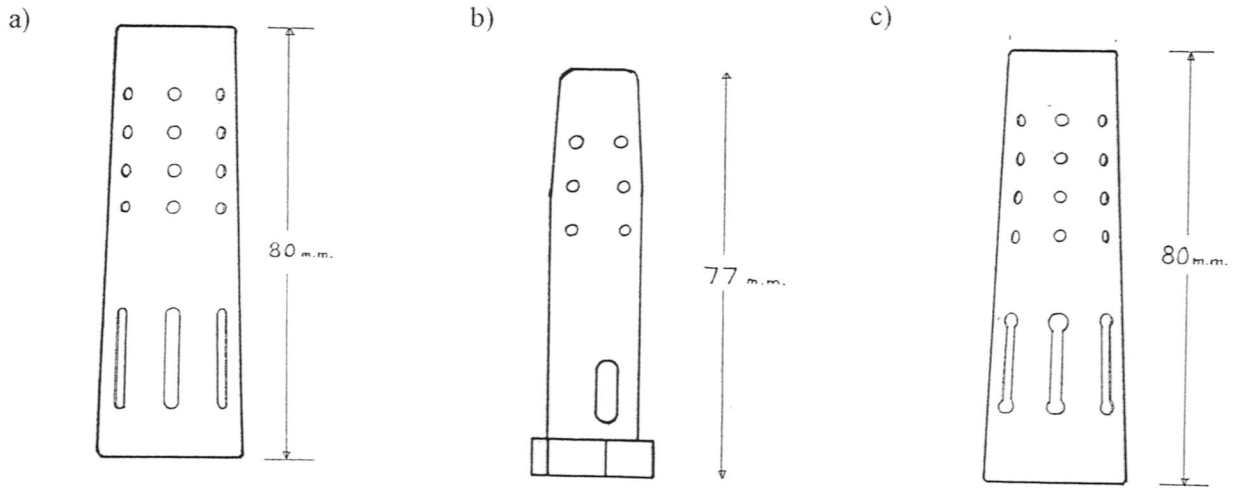

**Filler Caps**

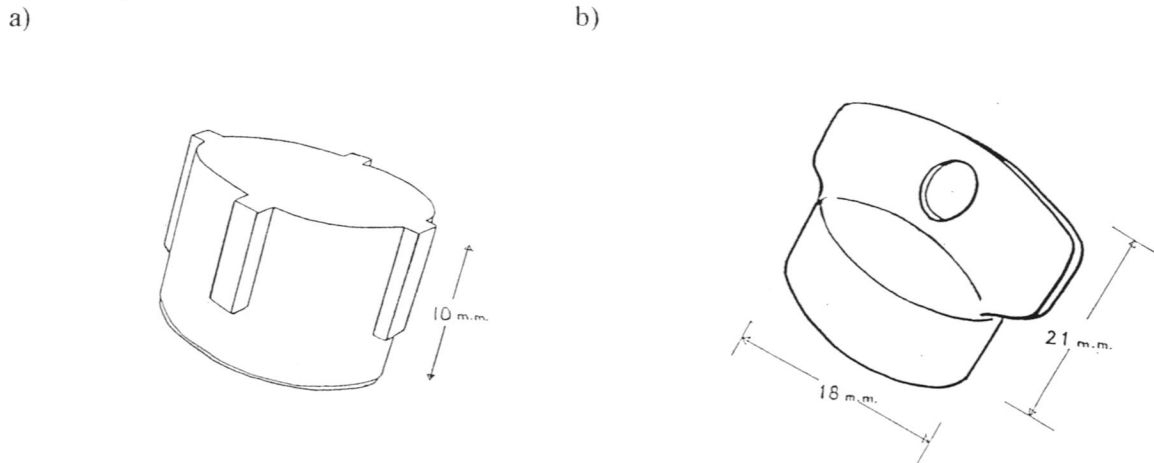

**Handles**

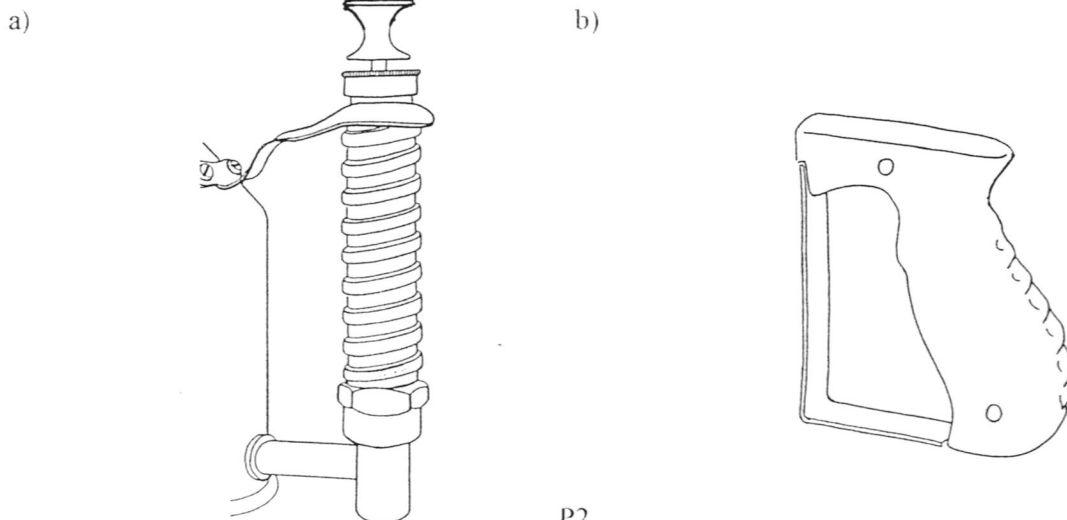

## Rally reminiscences 1998

Sheila Hawkins wrote briefly on their experiences in the 1998 Rally season. She confirmed that Keith was featured on the Antiques Roadshow and was also interviewed on Radio Stoke at the Etruria Canal Festival. This latter pointed to the benefit of publicity when she stated that at least one more person came to that show as the result of the broadcast!

Their overall impression of the season was RAIN - as seven of the shows were wet, very wet, and very windy.. The wettest being Lincoln and Parham. Good to fair weather blessed Old Warden, Honiton Hill, Leighton Buzzard, Chiltern and Enfield.

Other members joining them during the summer were Don Rixon at Old Warden and Leighton Buzzard -Lee McGuckian at, Honiton Hill, Ted Rawson at Lincoln and at Parham Dave Rees (*I still cannot get used to calling him that - Les*) She reported that Keith's collection increased by 42 lamps during the year with purchases in France, U.K. and Norway and swaps with Germany and France.

Weather apart their biggest complaint was with organisers who put the collections in inappropriate sections which made it difficult for other collectors to find them. For example at Barleylands they were classed as Arts and Crafts ( if you've seen Keith's waistcoat I think the organisers could be forgiven!) and at Chiltern, more reasonably perhaps, with the models

Thanks again Sheila for your reporting. She's fast becoming Blowlamp News' answer to Kate A die, and please note she is on page three !!

To add my comment to Sheila's I think perhaps as collectors are not revenue earning ,and by and large do not get expenses, they are regarded as tolerable admissions to shows. It has taken twenty six years for the directors of Stourpaine to recognise collectors by awarding a cup for the best display and at last we seem to be getting some recognition as an attraction for the public and to need adequate space to display our shows. Even that didn't help us cope with the mud at Blandford. The exodus was painful on Sunday & Monday!

### Members' questions

Tom Bartlett asks for information on the ACME torch ( so far as I know it is the only other British soldering torch with the Lamb. And one by "Proco Loa Hat" -I hope I have read his writing correctly -which he thinks might be German. Tom also reports with some satisfaction that the Dutch dealer who was offering lamps at such extortionate prices at Stourpaine had the same prices **and the same lamps** at Barleylands. I hope no one gave in to that.

He also said that John Wheeler had shown him a picnic stove with an oval brass plaque soldered on it stating "Coleman/Monitor" Anyone any other info on this. Taymar /Coleman is well known but I've not come across the link with Monitor.

In his letter Tom also says he bought a lamp in America which is named "The Phoenix No 3". It has a 1 pint cast alloy cone-shaped tank which is filled through the tank base. He says the burner looks American but has no further information. He has drawn a sketch of it but I'm sure I shall have to ask him to photograph it !

Two lads at Stourpaine averred that they had seen a " Harley Davidson" blowlamp which sported the famous American H-D motor cycle logo. I was given a rough sketch which was rather like a taller version of a Wall .The tank was possibly steel with a red painted wooden handle and the usual soldering bit hook on the top of a cast bronze burner. The logo is apparently stamped in relief on the side of the tank. They did not follow this up with any proof as I had requested, so I pass the question on.

Al Austin, one of the American collectors I met at Mt Vernon, has an unmarked Belgian looking lamp which had had a replacement control knob and wooden handle. The filler was the same type with the tall central safety valve column but instead of the hexagonal base it was round. Below is a sketch of the only marking remaining on the lower handle bracket. It was indistinct but possibly resembled a sledge. Any of our sharp eyed friends on the other side of La Manche know what this is ?



At Stourpaine John Tingle showed me a lamp which I photographed and have drawn for you to help him to identify it. It stands 4 1/2 inches high and the collar rotates to engage one of three different jet systems through the tubes projecting from the back of the lamp. It is a well finished article and the only markings are connected with the three positions of rotation of the collar. Any ideas?



### **Wanted**

Brian Grainger asks if anyone can sell him the extension hose and connectors for remote operation of the six pint Monitor brazing lamp. Phone. 01275 - 847155

### **Welcome to new member**

John **CLARKE** 117 Lindsey Road Dagenham Essex RM8 2RB 0181 252 759777

In case the significance of this year's Christmas Card is not immediately clear the connection with the first American Blowtorch Collectors' Convention is the obvious clue. Further (though not a lot of people know this) in 1884 the Statue of Liberty was given by France to the U S A. Technically it was designed by French sculptor Frederic Bartholdi and constructed of 300 sheets of copper 3/32 in thick over an iron frame designed by Eiffel (of the Tower). It stands some 300 feet tall on its plinth and bears the largest torch in America which is 21 feet high. There is a quarter scale replica on an island in the Seine. !! Now try me with some *Trivial Pursuit* questions !

### **Meetings**

As I mentioned in B/N 26 the Belgian meeting is planned for March 13<sup>th</sup> with the venue and other details to be announced

I hope to do a recce to plan our Spring meeting which should, I think, be in early May at a similar time to last year. I'll need to get another extra newsletter out for this and to give details of the Belgian meeting when they are available.

Finally my best wishes to you all for Christmas and the New Year.

Happy hunting