

# *Blowlamp News*

No 13

November

1995

Fallen leaves and the first frosts of winter are a far cry from the warm days of early September when so many members met each other, often for the first time, at Stourpaine.

We had intended that the reunions should have been at 11 and 4 but in some cases it resulted in 11 until 4 !. Still no matter, it was a most enjoyable experience and one which we hope to repeat, and possibly improve upon, in the future. I'm waiting to see the photographs. One suggestion is that since some people find it a problem to come so far South we should start a similar rendezvous further North, where there is a suitably large show. Lincoln has been suggested - are there any other ideas? Now the inevitable apology - apart of course for the lateness of B/N 13! How many of you spotted in the small print that **copywrite** is in fact **copywrong**! Please insert **copyright**!

One of the sad things about having to put such a formal statement in our informal newsletters is that we are aware that they are being reproduced and passed on to non-members. We certainly know of one member and have a suspicion of another. The most unfortunate thing is that one of the individuals to whom the letters are being passed professes not to be interested in joining us but still wishes to be in on the information being exchanged!

It is quite acceptable to send a copy to a prospective member and a number have joined us in this way, but to do it regularly is quite unfair to the others who cheerfully (or otherwise!) pay their subs each year. Nothing can be done about it except to hope it stops.

Enough of the sermon - now let's get on with B/N 12 comments.

Many of you liked the four page format but to continue with this needs more material to come in for publication so let's have some articles in the form of members letters. I receive a considerable number of letters during the year but they are not all in the form suitable for publication, unless I extract from them a paragraph or two for the newsletter. I would not of course do this without the writer's consent, so if you wish me to use any of your correspondence please say so when you write.

I'm sure it would be of interest if some of you who exhibit could give a short report about your views on the shows you attend. If the views are favourable it might encourage others to visit and arrange further meetings of members. This is perhaps something to look for in the later newsletters of the year, and to be followed by advance information on future shows where members are exhibiting.

The coloured badge display I had on show was considered suitable so I am proceeding with having some made. I'll let you know details of cost etc. when this is available, then I can start taking orders. Already several have put their names down for badges. There was some discussion at Stourpaine about other uses for the badge motif. Plastic car stickers, T-shirts and baseball hats were talked about, and I have already mentioned in B/N 12 about large size badges for exhibitors to show on their displays that they are members of The Blowlamp Society. This I feel could be good publicity.

**Update on B/N 11 logos.** We are indebted to Philippe for a lot of information about **Hahnel**. They were formed in 1885 and made a large range of lamps including many 2 pint steel tanked lamps for the German Army. He says the number 35 on some lamps refers to the capacity of 0.35 litre. Roy Edwards' 2 pint lamp should be designated No 30 and it is a copy of the Sievert HLL. My "E H T" ( See B/N 12) is an abbreviation for "Ernst Hahnel Taschenlotlampe" meaning Hahnel Pocket Blowlamp. Many thanks Philippe. Now who else has any information on Hahnel

The "V" within the inverted shamrock is undoubtedly Veritas. At St. Agnes I saw a 1 pint paraffin lamp ( 7 holes NOT 9!) with a complete transfer. This was a flat diamond shape with the name Veritas in script across the middle and a tiny replica of the "Shamrock and V" at the top of the diamond.

What is also interesting is that at a boot-sale recently I saw yet another small paraffin wick lamp with this logo on its base, as in the other two I've written about, but the small wick control knob disc was embossed "Falks - London." John Byrne has written in the past about a Falks blowlamp he has. It is a 1 pint paraffin which resembles a Veritas but the handle is different. Its transfer is rectangular with the name FALKS in large letters and the words "paraffin" "pressure" underneath and Made in England. I'll try to get some more detail after I next visit John.

I see I did not report that the newly acquired Otto Bernz of the same size as the Primus 848, Imp and Lamb Junior bears the number 7. No news yet about its burner shape.

One comment on the "crazing" on the surface of some lamps is that it occurs in certain Copper/zinc mixes used in the brass of different manufacturers. My experience, though very limited, is that only the tanks seem to be affected. The pumps and burners of my lamps appear normal. Anyone else have this problem?

### B/N 12 Filler caps.

These were all fitted with spring loaded safety valves which unfortunately I've not so far been able to dismantle. Hopefully I can present some exploded drawings of such safety devices in later B/N

a) a cap common to several Belgian lamps, notably Brevete It is not very common to have a hexagon shaped filler since hand tightening is all that should be necessary if the washer is in good condition The spanner or key needed for this is quite big to be in any sort of service kit. and, in any case, over tightening with a spanner would shorten the life of the washer. There seem to be plenty of Belgian lamps in the S.E. but we don't know a lot about them. They all seem to be of very similar tank and burner shape and all of half-pint petrol type. Anyone disagree?

b) I have this on both paraffin and petrol Radius lamps. It doesn't seem to be essential on the paraffin lamp so it might well be a substitute. One of mine appears to be nickel plated- original rather than workshop plated. In this respect, I have a Primus 633 which has a plated handle and burner bracket. As it was purchased at a boot-sale in Portsmouth it was probably the spare time "tarting up" by one of the workers in Pompey Dockyard. One occasionally sees a plated lamp, but I doubt if they were factory originals in that condition. I have a plated Sievert Vapouria No 4 but since the filler cap bears signs of having been attacked with a toothed or serrated wrench and the plating is intact within the tooth marks I believe the plating was not original. Anyone disagree? Incidentally, to digress from Radius and while still on the subject of Sievert, does anyone know the difference between Vapouria No. 4 and No 114 ?

c) Is rather a battered filler from an old Easilit petrol lamp. These were interesting lamps produced for several years by a small firm in Birmingham and inevitably taken over by one of the Big Boys and put out of business with loss of records etc. They patented double control knobs set at right angles to facilitate lighting. This was termed the Yates Patent and led to the Brand name "Easilit". A similar control system is seen on Burrige lamps but there is no evidence that these lamps were in any way connected . The patent for the Burrige lamps system was accorded to a man named Adams ( No relative!). It's a puzzle that two such similar lamp controls should have different patents. I'll try to get some more information to do a bigger article on Easilit later if people will send me pictures, drawings and general information on the subject.

### B/N 12 handles.

a) a newish Sievert seen on half-pint petrol lamps. The name Sievert is stamped in upper case letters in relief along the length of the handle. The handle is soldered to the tank body as appears to be the common practice with Sievert. Has anyone seen any Sievert handles fixed by studs or nuts to the bodies apart from the latest pistol-grip type?

b) a Hahnel handle on a half pint petrol lamp. The "doughnut rings" are reminiscent of Barthel which is probably not very surprising, though their handle rings are of the same size.

**B/N 12 control knob.** These impressive cast iron moulded handles are common on Turner, Otto Bernz and Clayton & Lambert lamps from the early 1920 s or even earlier. Many people confuse dates printed on many American lamps, believing that such dates were the date of manufacture. They are, in fact, the date the patent was first granted and the lamp may have been made many years after that time

**B/N 12 logo.** This lesser known logo is of the Detroit Torch and Manufacturing Company.

I know nothing about them

to many American

above. What is

soldered on to the shoulder

in any other American lamps.

marketed by the owner of the Trademark or logo and were made by someone else. Has anyone else seen a Detroit"?



but do have a two pint petrol lamp similar lamps. It also uses the cast iron control as significant is that the embossed brass plaque is of the tank. I've not come across this technique

Elsewhere it usually means that the lamps are only

You'll have found your two copies of my list of known makers or factors of blowlamps. and I make no excuse for any omissions.

This is in response to a number of requests (as I mentioned in B/N 12) by people wanting a list of all known lamps. What I hope is that you will be galvanised into listing the lamps you have against the names and adding any makers I've omitted that you may have. Then in the New Year send me one of the completed papers. The second is for you to keep up to date for your own records and perhaps send me details of new acquisitions. In time we may thus have a list of all the known lamps owned by our members. With the size of some of your collections I realise it might take some time. So here's a job for the long winter evenings!

Now for this edition's pictures.

**B/N/ 13 handles.**

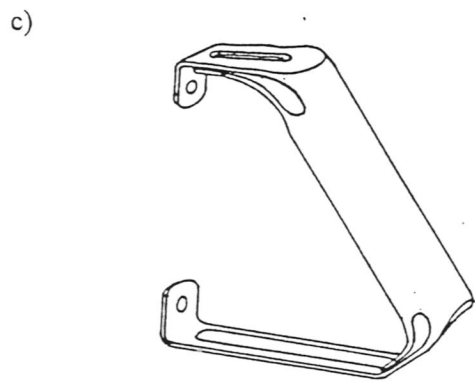
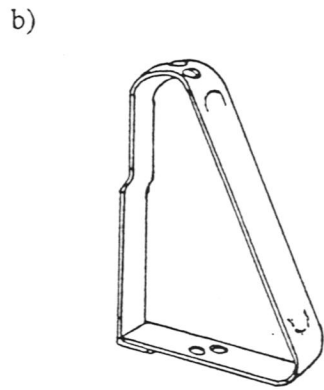
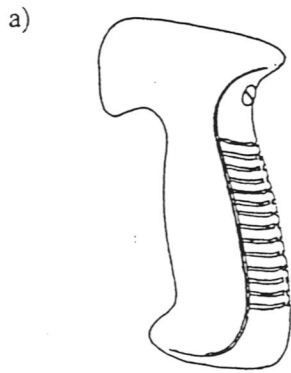

**B/N 13 filler caps**

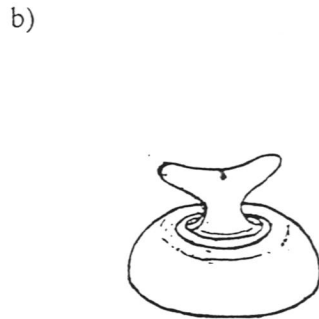

**B/N 13 pump lock**



**B/N 13 logo**



**B/N 13 what is it?**

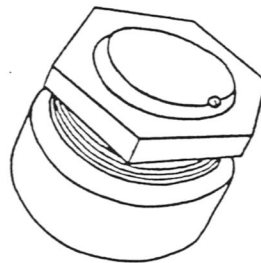

Welcome to some new members whose details will come in the December B/N with the updated address list:-

Dick Grenfell, John Wheeler, John Trippick, Stan Yelland, Colin Smith, Janus Nooyen, Mick Cook, Dave Ockenden, Gordon Buckland, Tony Clegg. I've probably omitted some but no doubt we'll catch up when the subs are due!!

This blank space is for one of your articles!

Cheers and best wishes,

